

ZAXIS-3 series Short-tail-swing version

HITACHI

ZAXIS
38U



HYDRAULIC EXCAVATOR

- Model Code: ZX38U-3
- Engine Rated Power: 21.3 kW (28.5 HP)
- Operating Weight: 3 790 - 3 960 kg
- Backhoe Bucket: 0.11 m³



Advances in Hitachi Design Prowess for Diverse Job Needs

The Hitachi new ZAXIS-U3 Series comes with a host of refinements and tougher body for higher durability and productivity.

Boosted Productivity (Page 4)

- The new engine delivers more power and higher operating efficiency.
- The Eco Zone, a new functionality, enhances fuel-efficient operation.
- Smooth combined operations for high production.
- The additional counterweight is equipped standard for higher stability when using a long or special attachment*.

*Extra piping is provided standard.

Higher Durability (Page 5)

- The boom cylinder guard is angled for added strength, protecting the boom cylinder from damage.
- The box-section blade stays are utilized, and the arm cylinder bracket and boom top bracket are strengthened.





Model Code: ZX38U-3
 Engine Rated Power: 21.3 kW (28.5 HP)
 Operating Weight: 3 790 - 3 960 kg
 Backhoe Bucket: 0.11 m³



Compact Body with Short Rear End

The compact short rear end design allows efficient operation even in confined spaces.



Enhanced Operator Comfort (Page 6)

- High backrest (cab).
- Short-stroke lever for long, continuous operation with less fatigue.

Higher Maintainability (Page 7)

- Centralised servicing points for simple daily maintenance and servicing.
- Split-type hydraulic hoses can be disconnected at the base and the boom back for quick replacement.
- Cooling fins at the radiator and oil cooler well avoid dirt packing and ease cleaning.

Enhanced Safety (Page 7)

- The neutral engine start mechanism allows the engine to start only when the pilot-control shut-off lever is in the lock position.
- ROPS/TOPS cab and canopy.

Notes: Some of the pictures in this brochure show an unmanned machine with attachments in an operating position. These were taken for demonstration purposes only and the actions shown are not recommended under normal operating conditions.

Boosted Productivity

The new engine is teamed up with the new hydraulic system to yield more production with less fuel consumption. The Eco Zone is a new fuel-efficient feature.



- **The new engine complies with the Emission Regulations EU Stage III A**



Eco zone



Additional counterweight

The new engine, combined with the new hydraulic system, boosts power and operating efficiency. The Eco Zone helps slash fuel consumption while yielding high production.

The Auto-Idle further cuts fuel consumption: When shifting the control lever to neutral, the engine slows automatically down to idling speed after four seconds later. This reduces emissions and sound as well. The proven 3-pump hydraulic system yields smooth combined operations for high production.

During high-speed traveling, travel motor speed decreases automatically when subjected to heavy load as in steering, and resumes when the load reduces. High/low speed shifting is smooth, too.

The additional counterweight comes standard for higher stability when using a long or special attachment.



Rugged Body for Tough Operation

The front attachment and blade are strengthened for higher durability and productivity at tough job sites.



Reinforced Front Attachment

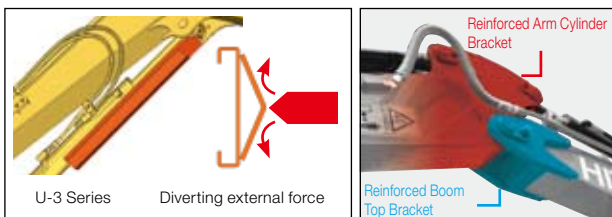

The boom cylinder guard is angled for added strength, and the arm cylinder bracket and boom top bracket are strengthened, too.

Reinforced Undercarriage

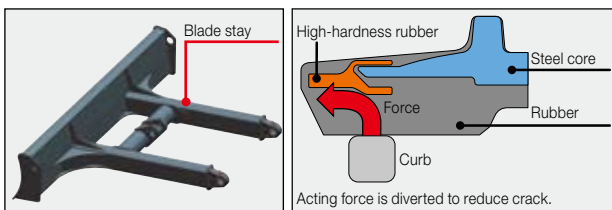

The box-section blade stays are utilized to increase ruggedness for productive leveling. Each track shoe is reinforced with a steel core. So, the edge of track shoe has improved resistance to damage when riding on road shoulder, for example.

Reinforced Upperstructure

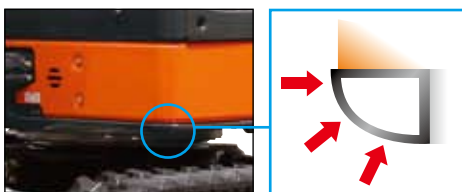

The job-proven D-section frame skirt is utilized to protect the frame skirt from damage.

Enhanced Operator Comfort

The high backrest and short-stroke levers come standard to enhance operator comfort.

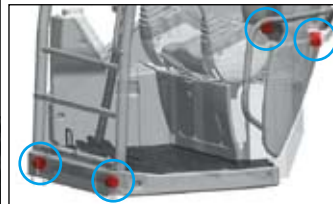
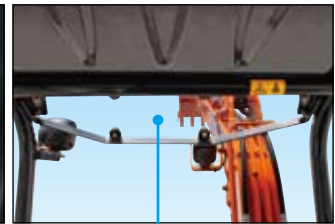

Shock-absorbing rubbers

Operator comfort is further enhanced with an array of sophisticated designs: bright cab interior color scheme, high backrest, short-stroke levers, wrist-rest, retractable seat belt, air conditioner, AM/FM radio, and roof visor (canopy). The cab itself rests on the field-proven four shock-absorbing rubber mounts for pleasant ride.



Short-Stroke Lever

Wrist-rest

Simple Maintenance and Safety Features

Hitachi design expertise eases pre-start check, shortens cleaning time, and simplifies daily servicing.



Simplified Maintenance

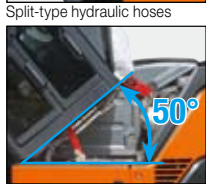

Split-type hydraulic hoses

The engine cover slides up and down for easy servicing in confined space. The cab floor can be tilted up to 50° for easy access to the floor bottom and engine rear.

Waved fins at the radiator and oil cooler well avoid dust packing and ease cleaning.

The split-type hydraulic hoses can be disconnected at the base and boom back for quick replacement if a hose is punctured.

Note: In daily maintenance, there is no need for cab tilting-up.

Safety Features

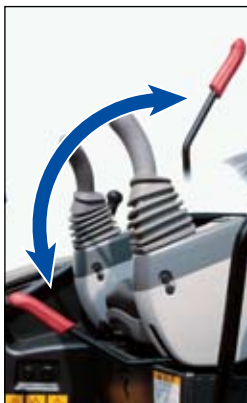

Illustrated is ROPS/OPG cab (with top guard).

When shifting the pilot-control shut-off lever upward, front action, swing, travel and blade action can all be locked to avoid misoperation due to unintentional lever handling. The neutral engine start system allows the engine to start only when the pilot-control shut-off lever is in the lock position.

What's more, the swing and travel parking brakes are equipped standard for easy operation on slope.

The world-class cab, conforming to the ROPS, TOPS and OPG top guard (level 1) standards, is utilized for operator protection.

*ROPS: Roll-Over Protection Structure
TOPS: Tip-Over Protection Structure
OPG: Operator Protective Guards*

SPECIFICATIONS

ENGINE

Model	Yanmar 3TNV88
Type	4-cycle water-cooled, direct injection
No. of cylinders	3
Rated power	
ISO 9249, net	21.3 kW (28.5 HP) at 2 400 min ⁻¹ (rpm)
EEC 80/1269, net ...	21.3 kW (28.5 HP) at 2 400 min ⁻¹ (rpm)
SAE J1349, net	21.3 kW (28.5 HP) at 2 400 min ⁻¹ (rpm)
Gross	22.0 kW (29.5 HP) at 2 400 min ⁻¹ (rpm)
Maximum torque	106 N·m (10.8 kgf·m) at 1 000 min ⁻¹ (rpm)
Piston displacement ..	1.642 L
Bore and stroke	88 mm x 90 mm
Electric system	
Voltage	12 V
Batteries	55 Ah
Alternator	55 A
Starter motor	2.3 kW

HYDRAULIC SYSTEM

Main pumps	2 variable displacement axial piston pumps 1 gear pump
Maximum oil flow ...	2 x 38.4 L/min 1 x 25.2 L/min
Pilot pump	1 gear pump
Maximum oil flow ...	10.8 L/min
Auxiliary	
Maximum oil flow ...	63.6 L/min

Hydraulic Motors

Travel	2 variable displacement axial piston motors
Swing	1 axial piston motor

Relief Valve Settings

Implement circuit	24.5 MPa (250 kgf/cm ²)
Swing circuit	16.7 MPa (170 kgf/cm ²)
Travel circuit	24.5 MPa (250 kgf/cm ²)
Pilot circuit	3.9 MPa (40 kgf/cm ²)
Auxiliary circuit	24.5 MPa (250 kgf/cm ²)

Hydraulic Cylinders

High-strength piston rods and tubes. Cylinder cushion mechanisms provided in boom and arm cylinder to absorb shock at stroke ends.

Dimensions

	Quantity	Bore	Rod diameter	Stroke
Boom	1	85 mm	50 mm	576 mm
Arm	1	75 mm	45 mm	597 mm
Bucket	1	65 mm	40 mm	435 mm
Blade	1	95 mm	45 mm	140 mm
Boom swing	1	85 mm	45 mm	525 mm

Hydraulic Filters

Hydraulic circuits use high-quality hydraulic filters. A suction filter is incorporated in the suction line, and full-flow filters in the return line.

CONTROLS

Hydraulic pilot controls levers for all operations.

Implement levers	2
Travel levers with pedals	2
Blade lever	1

NOISE LEVEL

Noise level (LwA) (2000 / 14 / EC)	95 dB (A)
Noise level (LpA) (ISO 6396)	79 dB (A)

UPPERSTRUCTURE

Revolving Frame

Welded sturdy box construction, using heavy-gauge steel plates for ruggedness. D-section frame for resistance to deformation.

Swing Device

Axial piston motor with planetary reduction gear is lubricated by hydraulic oil. Swing circle is single-row, shear-type ball bearing with induction-hardened internal gear. Internal gear and pinion gear are immersed in lubricant. Swing parking brake is spring-set/hydraulic-released disc type.

Swing speed	9.0 min ⁻¹ (rpm)
Swing torque	5.47 kN·m (558 kgf·m)

Operator's Cab

Independent spacious cab, 960 mm wide by 1 520 mm high, conforming to ISO* Standards. Reinforced glass windows on 4 sides for visibility. Front windows (upper and lower) can be opened. Reclining seat.

* International Standardization Organization

UNDERCARRIAGE

Tracks

Tractor-type undercarriage. Welded track frame using selected materials. Side frame welded to track frame.

Numbers of Rollers and Shoes on Each Side

Upper rollers	1
Lower rollers	4

Travel Device

Each track driven by 2-speed axial piston motor through planetary reduction gear for counterrotation of the tracks. Sprockets are replaceable.

Parking brake is spring-set/hydraulic-released disc type.

Travel speeds	High: 0 to 4.4 km/h Low: 0 to 2.9 km/h
---------------------	---

Maximum traction force	27 kN (2 750 kgf)
------------------------------	-------------------

Gradeability	58% (30 degree) continuous
--------------------	----------------------------

WEIGHTS AND GROUND PRESSURE

Equipped with 2.47 m boom, 1.72 m arm and 0.11 m³ bucket (ISO heaped) rubber shoes 300 mm.

Cab type	Operating weight	Ground pressure
4-Pillars canopy	3 790 kg	34 kPa (0.35 kgf/cm ²)
Cab	3 960 kg	36 kPa (0.36 kgf/cm ²)

* (Operating weight with 0.11 m³ bucket, fully serviced, +80 kg operator ISO 6016).

SERVICE REFILL CAPACITIES

Fuel tank	40.0 L
Engine coolant	5.0 L
Engine oil	7.2 L
Travel device (each side)	0.6 L
Hydraulic system	56.0 L
Hydraulic oil tank	32.0 L

BACKHOE ATTACHMENTS

Boom and arms are of welded, box-section design. 2.47 m boom, 1.72 m and 1.32 m arms are available.

Bucket

Capacity ISO heaped	Width without side cutters	Weight
0.11 m ³	550 mm	80 kg

SPECIFICATIONS

DIMENSIONS

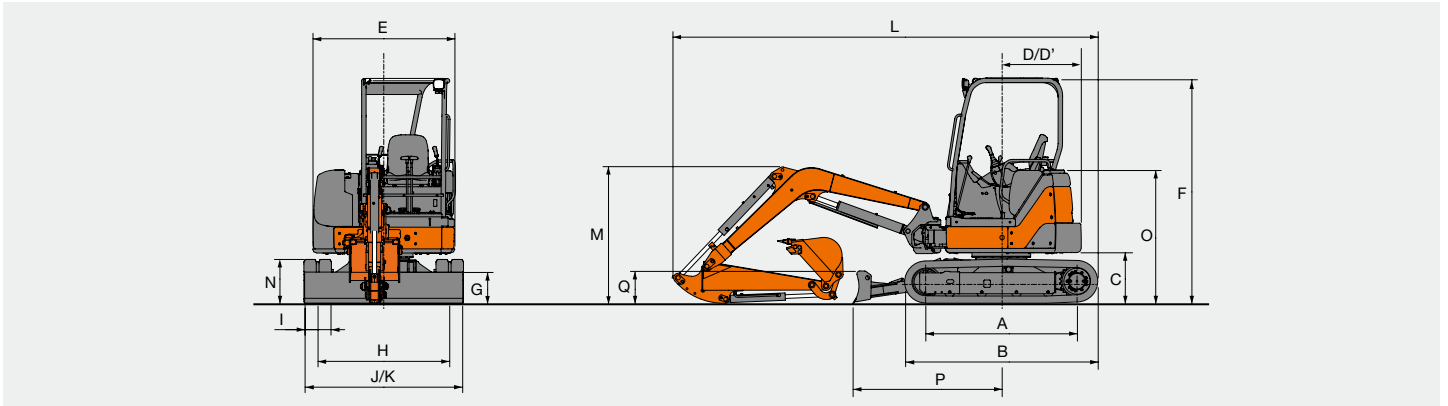

Unit: mm

Model code	ZX38U-3			
	1.32 m arm		1.72 m arm	
	Canopy	Cab	Canopy	Cab
A Distance between tumblers	1 650 (1 660)		1 650 (1 660)	
B Undercarriage length	2 100 (2 120)		2 100 (2 120)	
* C Counterweight clearance	550 (540)		550 (540)	
D Rear-end swing radius	960		960	
D' Rear-end length	960		960	
E Overall width of upperstructure	1 550		1 550	
F Overall height	2 460 (2 450)	2 500 (2 490)	2 460 (2 450)	2 500 (2 490)
* G Min. ground clearance	280 (270)		280 (270)	
H Track gauge	1 440		1 440	
I Track shoe width	300		300	
J Undercarriage width	1 740		1 740	
K Overall width	1 740		1 740	
L Overall length	4 650		4 780	
M Overall height of boom	1 490		1 910	
N Track height	480 (470)		480 (470)	
O Engine cover height	1 420 (1 410)		1 420 (1 410)	
P Horizontal distance to blade	1 610		1 610	
Q Blade height	355		355	

Data in () are dimensions of grouser shoe.

This illustration shows the ZX38U-3 equipment with 1.32 m arm, 0.11 m³ bucket and 300 mm rubber shoes

WORKING RANGES

Unit: mm

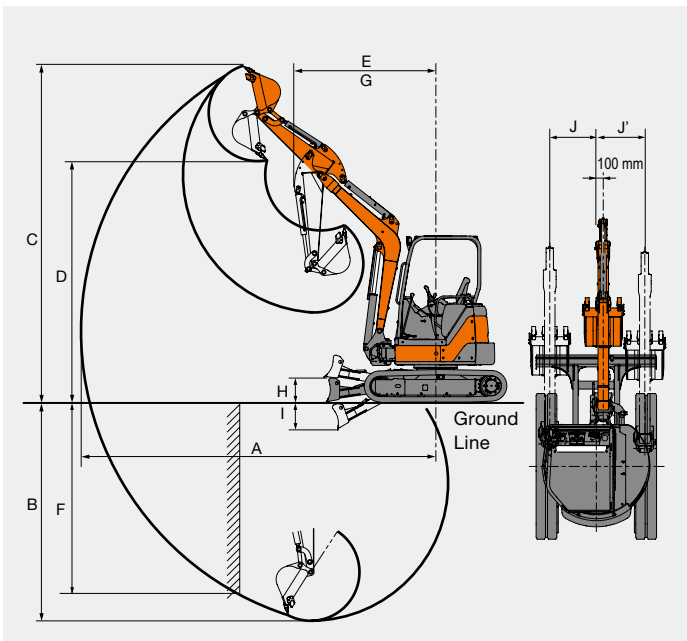

Model code	ZX38U-3			
	1.32 m arm		1.72 m arm	
	Canopy	Cab	Canopy	Cab
A Max. digging reach	5 210		5 520	
B Max. digging depth	3 050		3 450	
C Max. cutting height	4 870	4 710	4 950	4 760
D Max. dumping height	3 470	3 320	3 570	3 390
E Min. swing radius	2 070	2 230	2 170	2 300
F Max. vertical wall	2 590		2 800	
G Working radius at Min. swing radius (Max. boom-swing angle)	1 670	1 810	1 730	1 970
H Blade bottom highest position above ground	370			
I Blade bottom lowest position above ground	390			
J/J' Offset distance (Max. boom-swing angle)	605 / 740	605 / 700	605 / 740	605 / 700
Bucket digging force ISO: PCSA kN (kgf)	27.5 (2 800)		27.5 (2 800)	
Bucket digging force SAE kN (kgf)	23.0 (2 350)		23.0 (2 350)	
Arm crowd force ISO: PCSA kN (kgf)	19.1 (1 950)		17.2 (1 750)	
Arm crowd force SAE kN (kgf)	17.9 (1 830)		16.1 (1 640)	

This illustration shows the ZX38U-3 equipment with 1.32 m arm, 0.11 m³ bucket and 300 mm rubber shoes

LIFTING CAPACITIES

Notes: 1. Ratings are based on ISO 10567.

2. Lifting capacity does not exceed 75% of tipping load with the machine on

firm, level ground or 87% full hydraulic capacity.

3. The load point is the center-line of the bucket pivot mounting pin on the arm.

4. An asterisk mark (*) indicates load limited by hydraulic capacity.

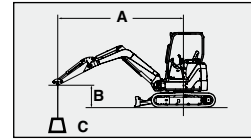

A: Load radius

B: Load point height

C: Lifting capacity

ZX38U-3 Canopy Version, Blade above Ground, 1.32 m Arm

Rating over-side or 360 degrees

Rating over-front

Unit: 1 000 kg

Conditions	Load point height	Load radius						At max. reach		
		2.0 m		3.0 m		4.0 m				meter
Rubber shoes 300 mm	3.0 m			*0.81	*0.81			0.53	0.55	3.93
	2.0 m	1.51	1.61	0.79	0.83	0.51	0.53	0.44	0.46	4.37
	1.0 m			0.74	0.77	0.49	0.51	0.42	0.43	4.49
	0 (Ground)	1.31	*1.39	0.71	0.74	0.48	0.50	0.43	0.45	4.33
	-1.0 m	1.32	1.42	0.71	0.74			0.50	0.52	3.86

Conditions	Load point height	Load radius						At max. reach		
		2.0 m		3.0 m		4.0 m				meter
Rubber shoes 300 mm Additional counterweight 230 kg	3.0 m			*0.81	*0.81			0.62	0.65	3.93
	2.0 m	*1.61	*1.61	0.92	0.96	0.60	0.62	0.52	0.54	4.37
	1.0 m			0.86	0.91	0.58	0.60	0.49	0.51	4.49
	0 (Ground)	*1.39	*1.39	0.83	0.88	0.56	0.59	0.51	0.53	4.33
	-1.0 m	1.55	1.67	0.83	0.87			0.59	0.62	3.86

ZX38U-3 Canopy Version, Blade on Ground, 1.32 m Arm

Unit: 1 000 kg

Conditions	Load point height	Load radius						At max. reach		
		2.0 m		3.0 m		4.0 m				meter
Rubber shoes 300 mm	3.0 m			*0.81	*0.81			0.53	*0.82	3.93
	2.0 m	1.51	*1.61	0.79	*1.06	0.51	*0.91	0.44	*0.80	4.37
	1.0 m			0.74	*1.42	0.49	*1.02	0.42	*0.86	4.49
	0 (Ground)	1.31	*1.39	0.71	*1.61	0.48	*1.09	0.43	*0.98	4.33
	-1.0 m	1.32	*2.57	0.71	*1.52			0.50	*1.03	3.86

Conditions	Load point height	Load radius						At max. reach		
		2.0 m		3.0 m		4.0 m				meter
Rubber shoes 300 mm Additional counterweight 230 kg	3.0 m			*0.81	*0.81			0.62	*0.82	3.93
	2.0 m	*1.61	*1.61	0.92	*1.06	0.60	*0.91	0.52	*0.80	4.37
	1.0 m			0.86	*1.42	0.58	*1.02	0.49	*0.86	4.49
	0 (Ground)	*1.39	*1.39	0.83	*1.61	0.56	*1.09	0.51	*0.98	4.33
	-1.0 m	1.55	*2.57	0.83	*1.52			0.59	*1.03	3.86

ZX38U-3 Cab Version, Blade above Ground, 1.72 m Arm

Unit: 1 000 kg

Conditions	Load point height	Load radius						At max. reach		
		2.0 m		3.0 m		4.0 m				meter
Rubber shoes 300 mm	3.0 m					0.55	0.57	0.49	0.50	4.30
	2.0 m			0.84	*0.85	0.54	0.55	0.42	0.43	4.69
	1.0 m			0.78	0.81	0.51	0.53	0.39	0.40	4.81
	0 (Ground)	1.36	1.45	0.74	0.77	0.49	0.51	0.40	0.41	4.66
	-1.0 m	1.36	1.45	0.73	0.76	0.49	0.50	0.45	0.47	4.24

Conditions	Load point height	Load radius						At max. reach		
		2.0 m		3.0 m		4.0 m				meter
Rubber shoes 300 mm Additional counterweight 230 kg	3.0 m					0.64	0.66	0.57	0.59	4.30
	2.0 m			*0.85	*0.85	0.62	0.64	0.49	0.50	4.69
	1.0 m			0.91	0.95	0.60	0.62	0.46	0.47	4.81
	0 (Ground)	*1.55	*1.55	0.86	0.90	0.58	0.60	0.47	0.49	4.66
	-1.0 m	1.58	1.70	0.85	0.89	0.57	0.60	0.53	0.55	4.24

ZX38U-3 Cab Version, Blade on Ground, 1.72 m Arm

Unit: 1 000 kg

Conditions	Load point height	Load radius						At max. reach		
		2.0 m		3.0 m		4.0 m				meter
Rubber shoes 300 mm	3.0 m					0.55	*0.71	0.49	*0.74	4.30
	2.0 m			0.84	*0.85	0.54	*0.79	0.42	*0.78	4.69
	1.0 m			0.78	*1.25	0.51	*0.93	0.39	*0.82	4.81
	0 (Ground)	1.36	*1.55	0.74	*1.54	0.49	*1.05	0.40	*0.88	4.66
	-1.0 m	1.36	*2.50	0.73	*1.57	0.49	*1.04	0.45	*0.94	4.24

Conditions	Load point height	Load radius						At max. reach		
		2.0 m		3.0 m		4.0 m				meter
Rubber shoes 300 mm Additional counterweight 230 kg	3.0 m					0.64	*0.71	0.57	*0.74	4.30
	2.0 m			*0.85	*0.85	0.62	*0.79	0.49	*0.78	4.69
	1.0 m			0.91	*1.25	0.60	*0.93	0.46	*0.82	4.81
	0 (Ground)	*1.55	*1.55	0.86	*1.54	0.58	*1.05	0.47	*0.88	4.66
	-1.0 m	1.58	*2.50	0.85	*1.57	0.57	*1.04	0.53	*0.94	4.24

EQUIPMENT

STANDARD EQUIPMENT

Standard equipment may vary by country, so please consult your Hitachi dealer for details.

ENGINE

- Water-separator for engine fuel
- Radiator reserve tank
- Electrical fuel feed pump
- Cartridge-type engine oil filter
- Fuel filter

HYDRAULIC SYSTEM

- Hydraulic pilot type control levers
- Pilot control shut-off lever with neutral engine start system
- Swing parking brake
- Travel parking brake
- Two-speed travel system
- Auto idling system
- Suction filter
- Full-flow filter
- Pilot filter
- Boom anti-drift valve
- Valve for extra piping

CAB

- ROPS/OPG cab
- Air conditioner
- AM/FM radio
- Window washer
- Defroster
- Reclining seat
- Suspension seat
- Retractable seat belt
- Wrist rests
- Spare power supply
- Wiper
- Drink holder
- Electric horn
- Cigarette lighter
- Floor mat
- Anti-slip plate
- Ashtray

UPPERSTRUCTURE

- Additional counterweight: 230 kg
- Tool box
- Rear view mirror (with cab)

UNDERCARRIAGE

- 300 mm rubber shoes

FRONT ATTACHMENTS

- HN bushing
- 1.72 m arm
- Extra piping

OPTIONAL EQUIPMENT

Optional equipment may vary by country, so please consult your Hitachi dealer for details.

ENGINE

- Engine control lever*

4-PILLARS CANOPY

- ROPS/OPG canopy
- Reclining seat
- Suspension seat
- Retractable seat belt
- Wrist rests
- Spare power supply
- Drink holder
- Electric horn
- Cigarette lighter
- Floor mat

CAB

- Heater

UPPERSTRUCTURE

- Pilot accumulator
- Theft deterrent system
- Multi-function lever (3 position switch type)
- Auxiliary overload relief valve

UNDERCARRIAGE

- 300 mm grouser shoes
- 300 mm pad crawler shoes

FRONT ATTACHMENTS

- 1.32 m arm

* An auto-idle function isn't added to this device.

These specifications are subject to change without notice.

Illustrations and photos show the standard models, and may or may not include optional equipment, accessories, and all standard equipment with some differences in color and features.

Before use, read and understand the Operator's Manual for proper operation.

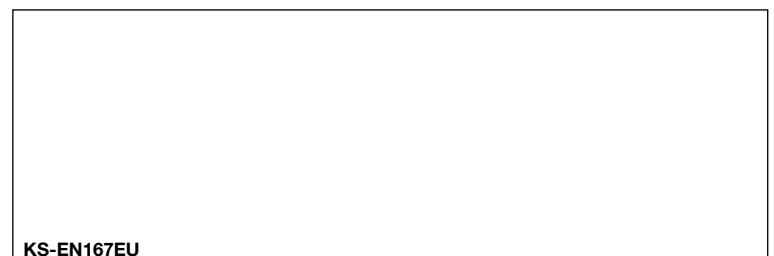

KS-EN167EU